



不懈努力 创造美好生活

户外木塑地板

—— 光脚丫® WPC ——



CD-01

产品介绍

DECKING

产品规格



型号	CD-01
截面图	
尺寸	140*21mm
表面	3D 木纹&沟槽
原料	50% 木纤维、38% HDPE、12% 添加剂
认证	FSC, CE, CNAS, ISO 9001:2019

CD-01双面不同的观感设计，同时享有沟槽和3D木纹两种表面。只需“翻转”，即可在两种风格之间切换！专为满足大人流高强度的需求而设计，良好适用于栈道、广场、步行街等。



防水防潮



使用寿命长



防虫防蛀



耐冲击



环保可回收



防刮花



高耐候性



易维护



防霉菌

产品特点



3D压花表面

1

- ◇ 灵感来自天然真木纹
- ◇ 压花深度超过 1 毫米
- ◇ 多达三种木纹样式供您选择

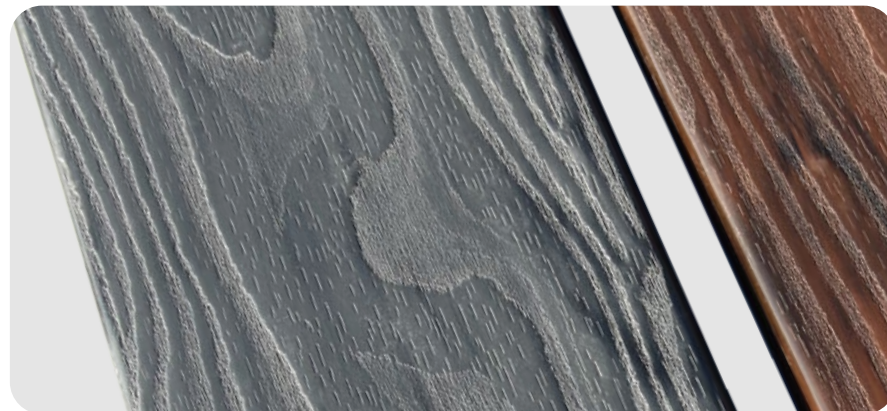

创新艺术色

2

- ◇ 多达5种艺术色可选
- ◇ 极好地融入各种装饰风格
- ◇ 抗褪色，长久保持质地稳定



优异性能

3

- ◇ 成熟的配方和技术
- ◇ 真实木质感
- ◇ 高度防霉、防刮、防裂、防潮

产品展示

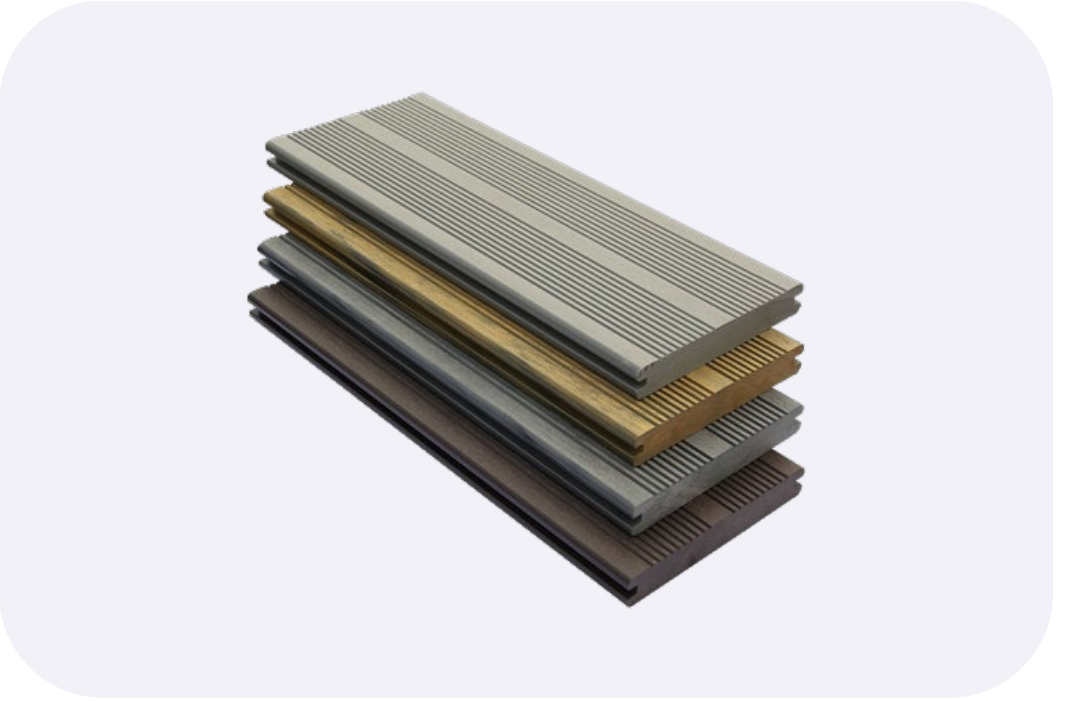

产品表面

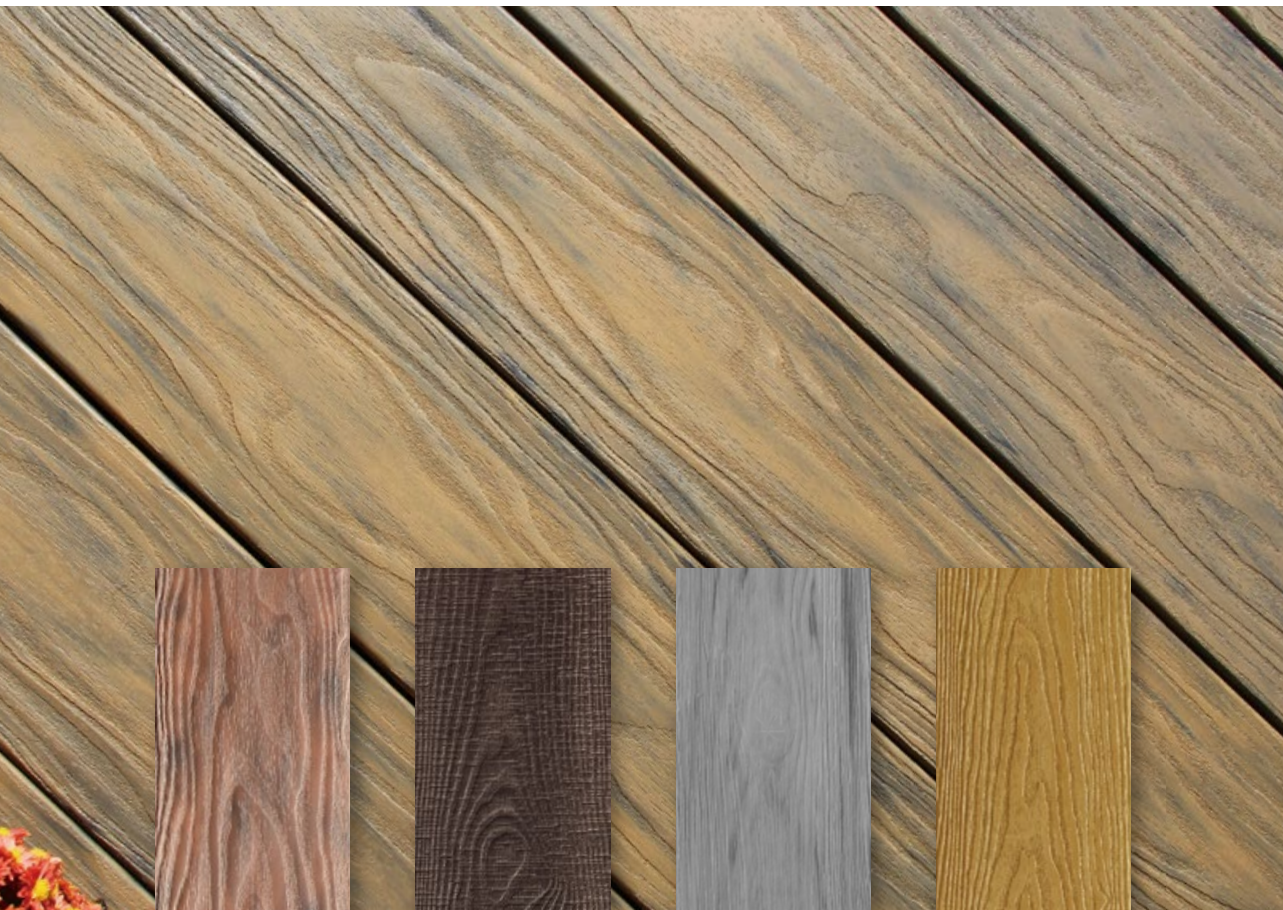

现代



古典



复古



时尚

颜色选项

艺术色系列



浅灰混



雪松混



红松混



红木混



红棕混

标准色系列



浅灰



雪松



红松



红木



红棕



咖啡



蓝灰

产品详情

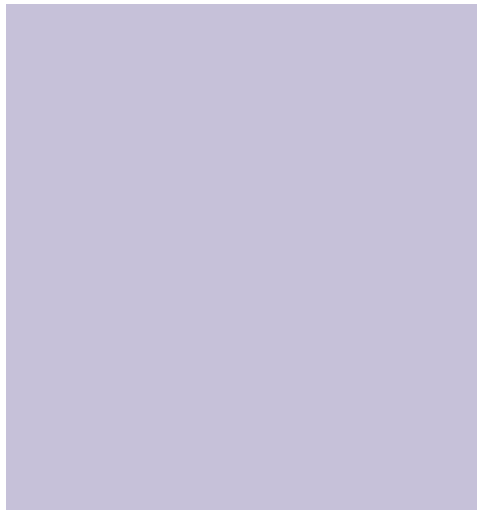

APPLICATION

项目展示

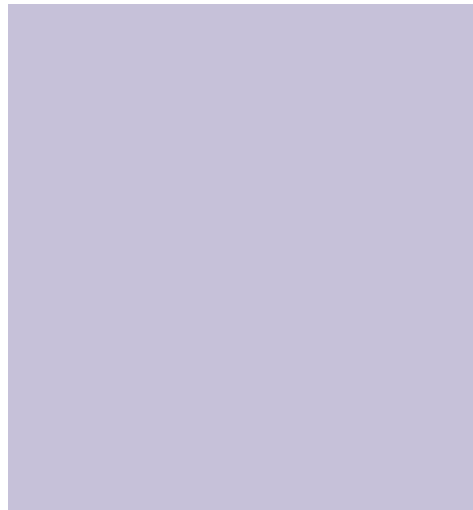
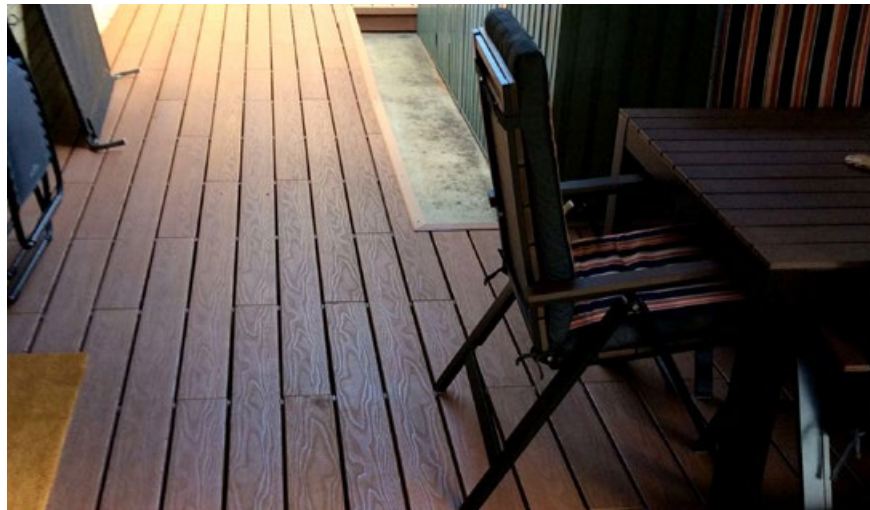
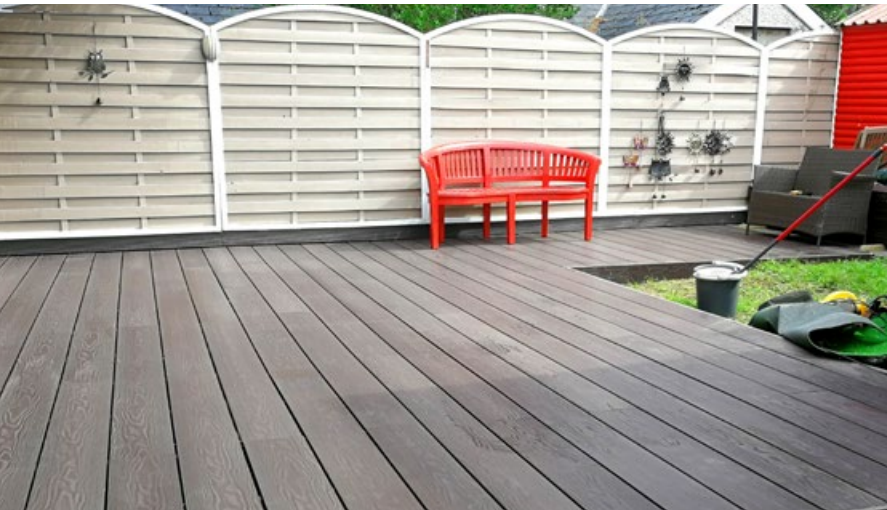

安装说明



电锯



冲击钻



电钻



水平仪



尺子



龙骨



护角



起始件



连接件



膨胀螺丝



螺丝

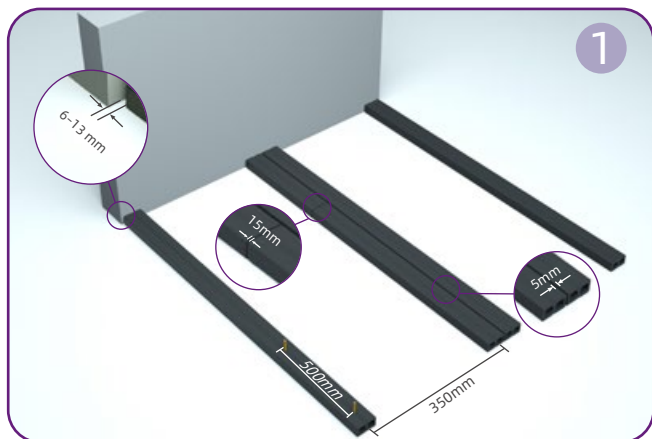

用膨胀螺丝将龙骨固定在地面上，龙骨间距不应超过 350 毫米。在地板之间的末端到接头处需要双龙骨。

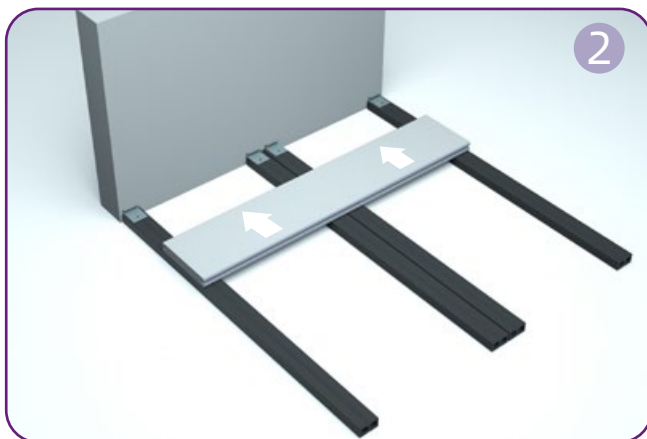

安装起始件并将第一个地板滑入起始夹。

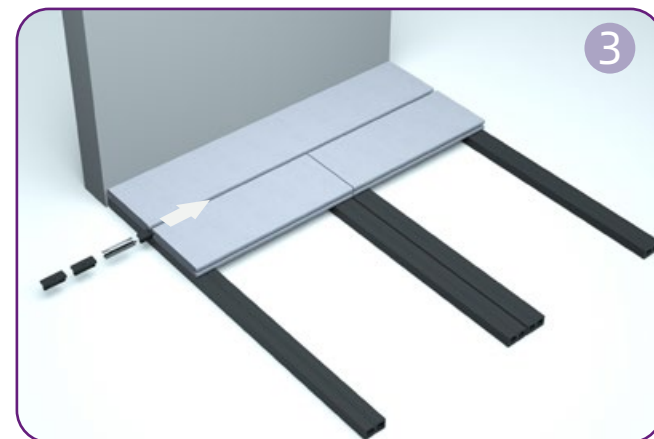

将连接件滑入地板槽中。

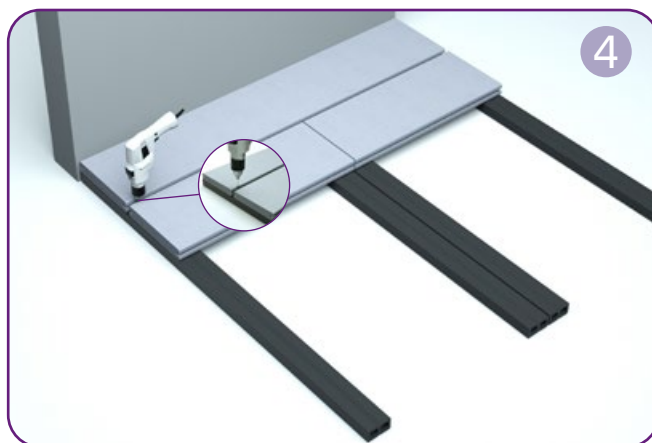

使用螺丝固定连接件。

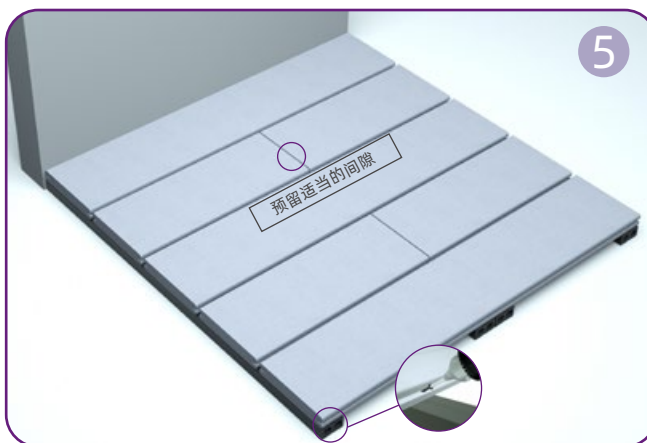

地板接缝处留出适当伸缩缝。边缘处，斜向打入螺丝以完成地板固定。

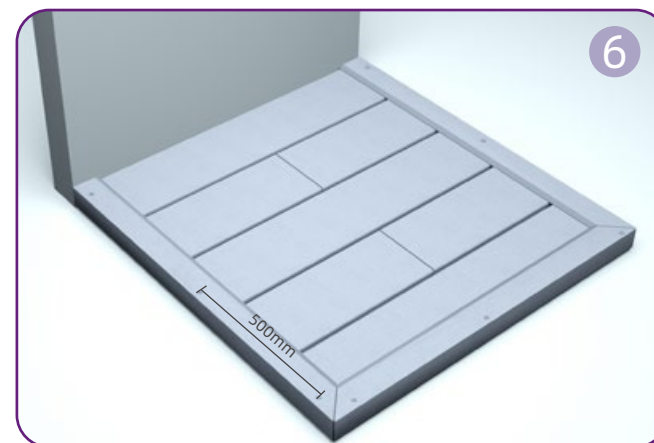

以合适的角度修剪L角并用螺丝钉固定。螺丝钉间距不超过500mm。

包装和运输

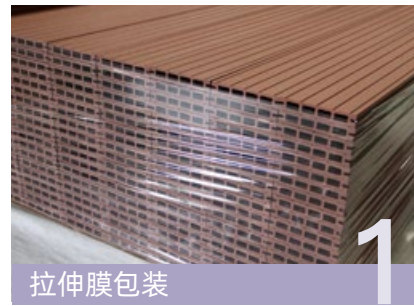

拉伸膜包装

1



纸箱包装

2



三合板覆盖

3



防水包装&包装带固定

4



仓库存储

5



货物装载

6

发货前，按照一套严格的包装程序，确保每一块货物都能安全地送达客户手中。

拉伸膜包装

纸箱包装

三合板覆盖

防雨布包装

包装带固定

关于光脚丫®

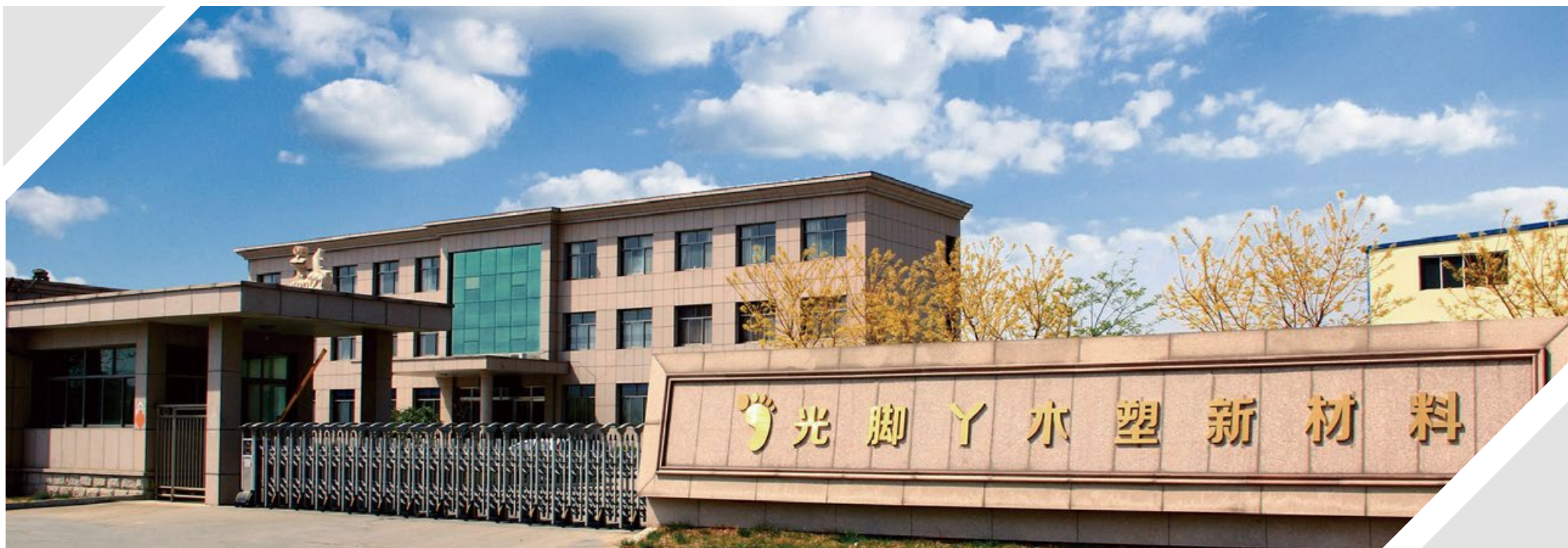

光脚丫®成立于2000年，是一家集木塑新材料研究与开发、生产销售、加工配套指导、进出口贸易、营销设计于一体的综合型企业，总部位于青岛。是国内较早就开始研究木塑新型材料的科技型企业，被誉为“中国木塑行业的领航者”。

企业使命/探索追求创新，生存服务生命；为创造人类健康生活环境，为世界和谐发展而努力奋斗！

企业愿景/打造光脚丫®一流木塑品牌，让光脚丫®木塑遍布全球；成为国际上户外装饰材料(WPC)和室内轻装饰材料(PWPC)领域最专业、最有价值的供应链组织者。

发展价值观/企业与员工共赢，企业与客户共赢，企业和对手共赢，企业与社会共发展。

- | | |
|------------|---|
| 2000年 | 光脚丫®引进木塑生产技术，定向出口加拿大； |
| 2006年 | 开启多元化经营； |
| 2008年 | 实施品牌经营策略，先后推出国外品牌：COOWIN®、BAREFOOT®、EvoDek®，和国内品牌：尊墅院落®、光脚丫®； |
| 2013年 | 扩建工厂，增加产能； |
| 2014-2016年 | 被中国官方认定为木塑品牌十强之一； |
| 2017年开始 | 持续追求技术创新和可持续发展； |
| 2019年开始 | 对内完善公司体系；对外实施全球战略伙伴计划； |
| 2020年 | 推出光脚丫®花园地板系列产品，为国内消费者提供舒畅的户外装饰地板。 |



不懈努力 创造美好生活

一路一程，尽是风景；永不放弃，让希望永生！